

Topic 2

Generating and Creating Ideas

Topics

- Thought Processes
- Experimentation
- Drawing
- Research
- Writing
- Analysis
- Evolving Ideas

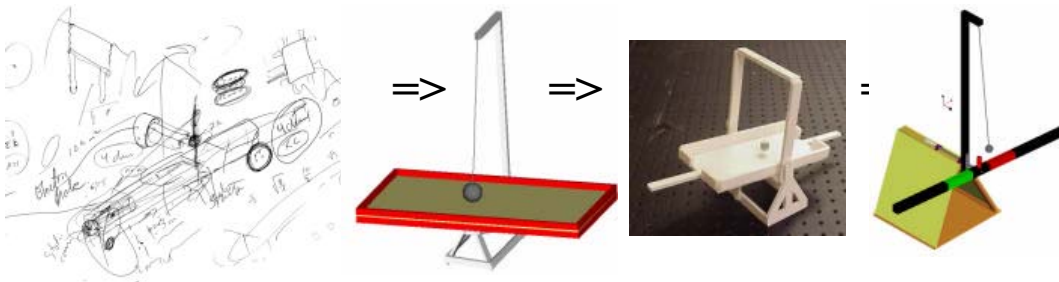

Thought Processes

- To help generate and create ideas, *thought processes* can be used as *catalysts*
 - Systematic Variation
 - Consider all possibilities
 - Persistent Questioning
 - Continually ask “Who?”, “What?”, “Why?”, “Where”, “How?”
 - Reversal: Forward Steps
 - Start with an idea, and vary it in as many ways as possible to create different ideas, until each gets to the end goal
 - Also called the *method of divergent thought*
 - Reversal: Backwards Steps
 - Start with the end goal and work backwards along as many paths as possible till you get to the beginning
 - Nature’s Way
 - How would nature solve the problem?
 - Exact Constraints
 - What are the minimum requirements

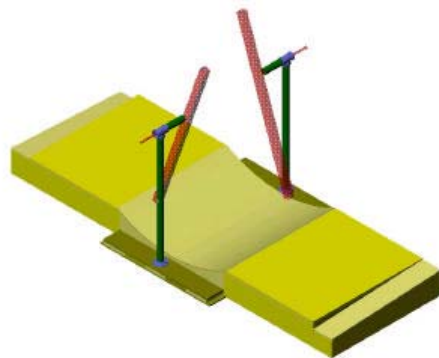



Thought Processes: *Systematic Variation*

Consider all possibilities:

- Energy: How can it be applied, generated, stored?
 - Mechanical: springs, flywheels...
 - Hydraulic: piston, bladder, reservoir, propeller...
 - Electrical: line source, battery, capacitor, magnet, optical...
- Material:
 - State: solid, liquid, gas
 - Behavior: rigid, elastic, plastic, visco
 - Form: bar, sheet, powder...
- Motions:
 - Type: fixed, linear, rotary
 - Nature: uniform, non-uniform, transi
 - Direction & Magnitude
- Controls:
 - Passive
 - Active

AND all combinations of the above!

Analytical models of systems are invaluable
Sensitivity studies can be easily conducted

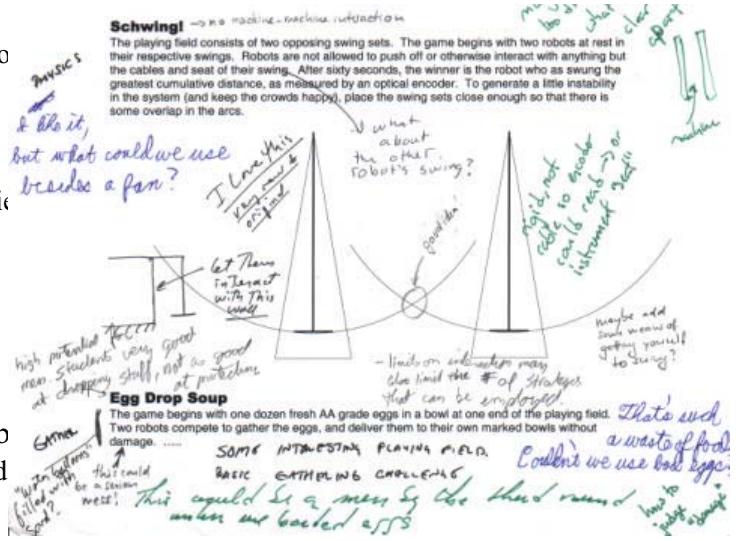
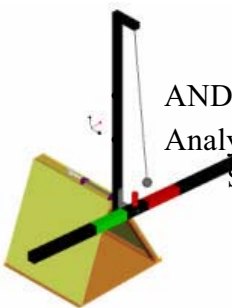
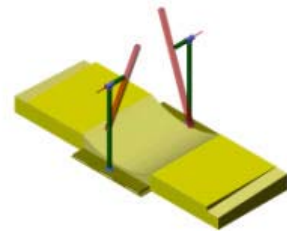

Thought Processes: *Reversal*

- Being able to rapidly switch between the methods of *Forward Steps* and *Backward Steps* is an invaluable skill
 - Example: Given length equalities indicated by the colored pointy end cylinders, prove that the yellow cylinder is the perpendicular bisector of the purple and red cylinders?
 - Never be afraid to add your own sketching to a problem that is given you
 - The thin red and blue lines and vertex labels were added!
 - If you do not rapidly see how to move forward, try going backwards!

As given:

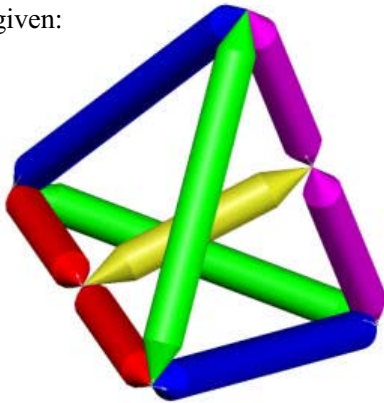

After user inflicted
clarifying features:

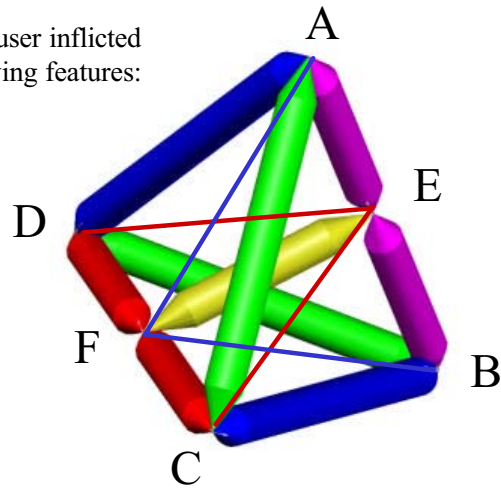

Experimentation

- Playing With Parts
- Sketch Models
- Bench Level Experiments
- Bench Level Prototypes
- Identifying Risky Ideas

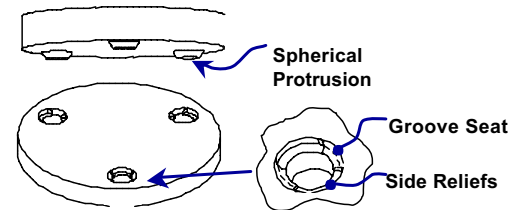
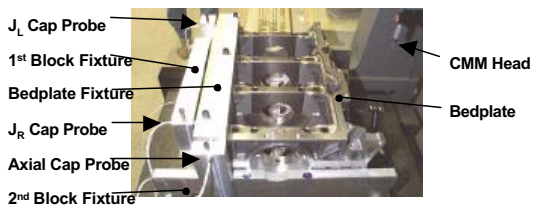
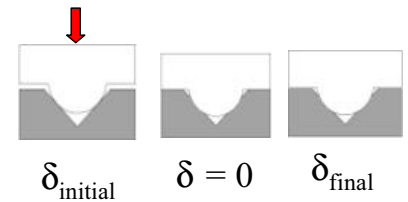
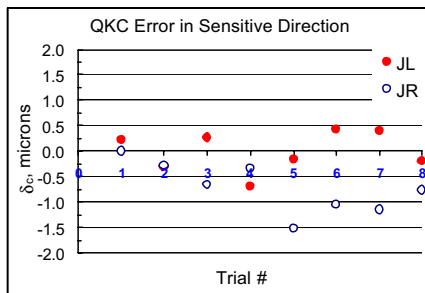
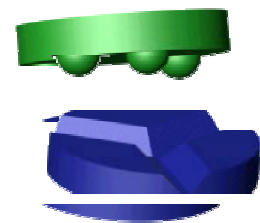
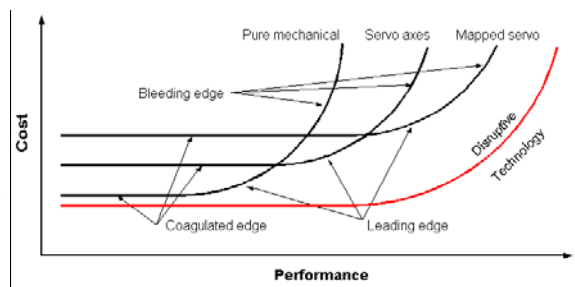

Experimentation: *Playing with Parts*

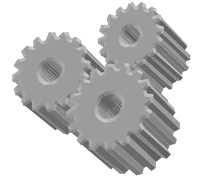

- Lay out all the materials you have (physically or information sheets) in front of you and play with them, let them talk to you, what are their limits, how have others used them...?
 - Place components amongst each other on the contest table to obtain a physical feel for how they might work and fit.....
 - Move the table and feel its motions....
- With a “competing” partner “drive” imaginary machines with your hands to feel how things might move in competition
 - Mock competitions can help create and evolve *strategies*

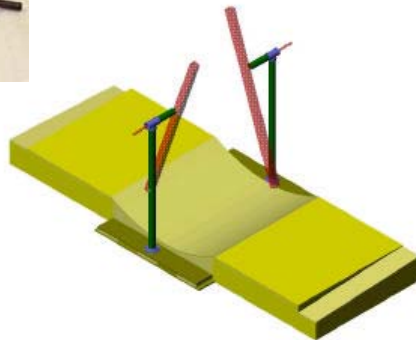



Experimentation: *Sketch Models*

- Sketch models are made from simple materials (e.g., cardboard, foam, hot-melt-glue, tape, string) and they allow you to literally “play” with potential **strategies**
 - Later, when you have a **concept** developed, they enable you to “test drive” your machine **concept** around the table
 - In the “real world” where designs are often very complex, sketch models are still often important “proof of **concept**” aids
 - They can be invaluable sales tools!
- A *Sketch-Model-Derby* is an invaluable way to test ideas, with minimal risk of time and materials
 - Evolution of *The MIT and the Pendulum*:

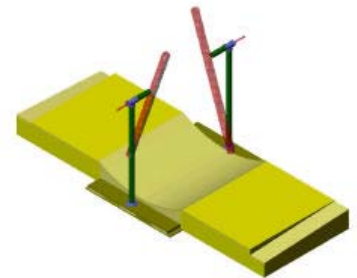

Experimenting: *Bench Level Experiments*

- Experiments to test function, force, friction, and speed, are a vital part of the design process
 - Analysis is potentially the quickest way to verify an idea
 - Remember, to be thorough! The first 4 letters of *analysis* are...
 - Analysis inexperience or uncertainty can lead to *analysis paralysis*
 - Analysis paralysis is most often relieved by a simple experiment

Example:

- Idea: Use a winch to pull the pendulum back and forth?
- Experiment: Tape a motor to the beam and tie a string around the pendulum and see if the motor shaft can wind the string up and pull the pendulum over
 - Does the motor's distance from the pendulum affect how far over it can pull the pendulum?

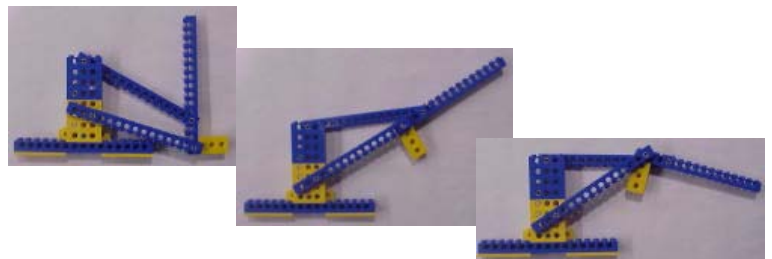
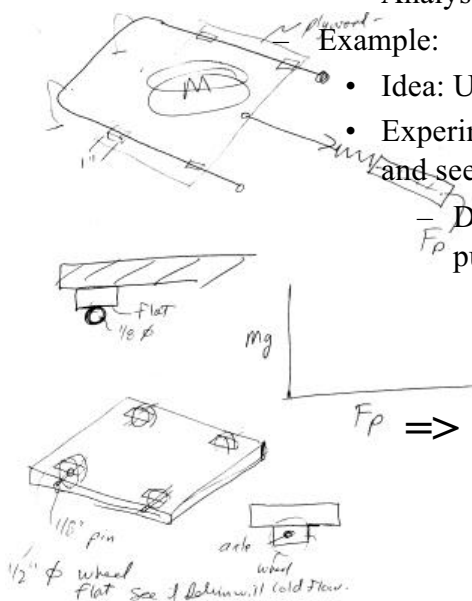

Experimenting: *Bench Level Prototypes*

- Once you get to the *concept* phase, you may have a risky idea, which if it works, would be awesome
 - A *Bench Level Experiment* was performed to prove the principle of an idea, but it is not a potentially functional part of the machine
- A *Bench Level Prototype* is designed to ideally be an actual *module* to test a risky *concept*
 - Design it well, and if it works, it could be a ready-to-use *module* for your machine!
 - It often shows what works and what must be fixed in a *module* (like the software!)
 - A robot contest BLP would be to create a vehicle to test its speed and controllability
 - Use modular *components*, so you can change them to optimize performance
 - E.g., change the gear ratio on a vehicle's drive train



© 2000 Alexander Slocum



2-9

Oops! Software crashed it again!



Programmers are not that innocent! 1/16/2002

Drawings

- Motion & Force Diagrams
- Sketches & Mock Battles
- Solid Models

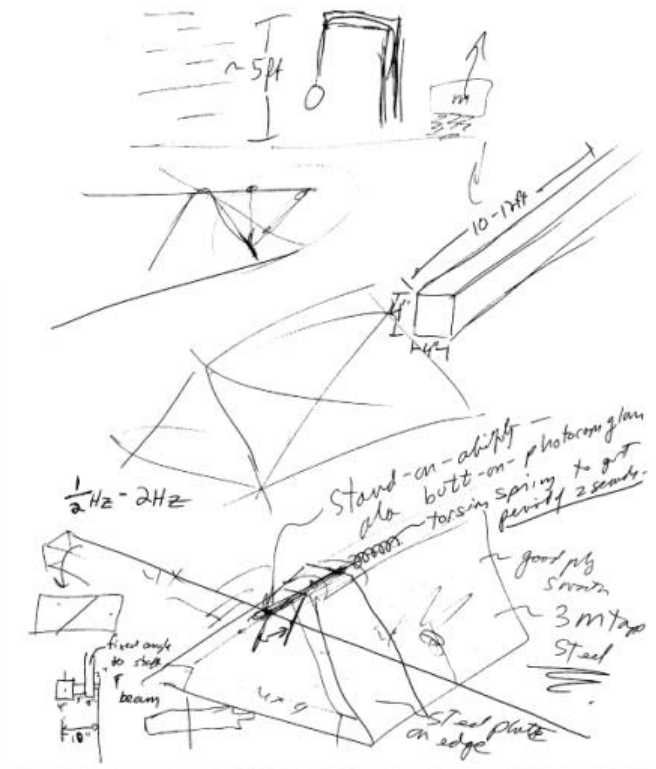
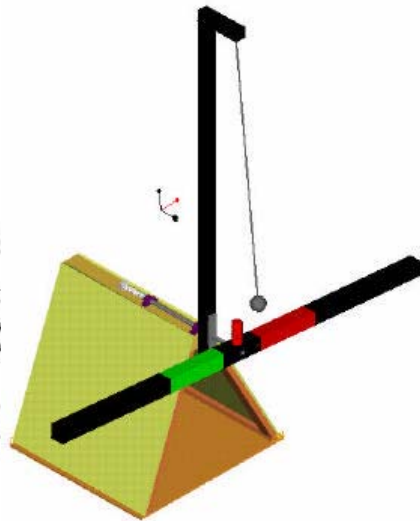
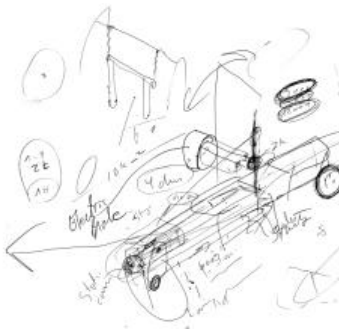
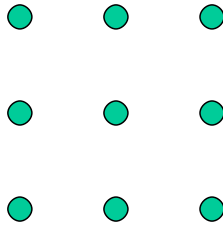

Drawing: *Motion & Force Diagrams*

- It is important to sketch the idea of a **strategy** without including any mechanical detail:
 - Just use arrows to indicate directions of motions
 - Illustrating the motion with mechanism implies a concept
 - Use different colors!
 - You do not want to start implying specific **concepts** because this could lead you to spend time developing it before you explore enough **strategies**
 - Time is precious
 - For an illustrative reference, read *If You Give a Mouse a Cookie*

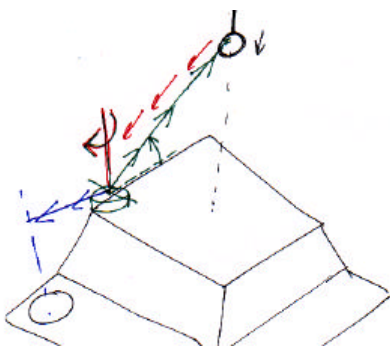

2000's *Sojourner This!*

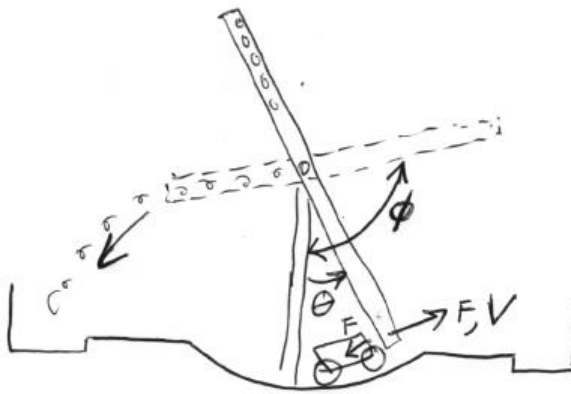

2002's *The MIT and the Pendulum*

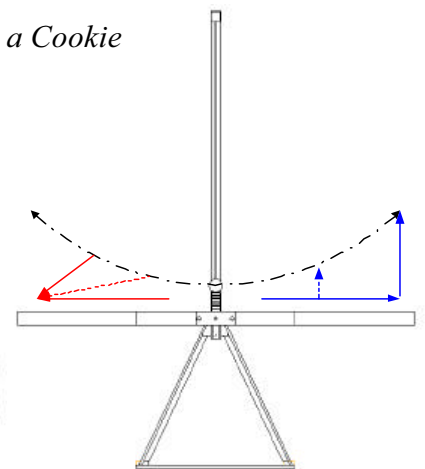

2001's *Tiltator!*

Drawing: *Sketches*

- **Strategies** are sketched with simple arrows to indicate motions
- **Concepts** are sketched showing overall design intent via possible mechanisms and blocks representing modules
- **Modules** are sketched showing basic types of components
- **Subassemblies** and **components** capture detail and design intent
- Pit your sketches against each other in mock competitions!
- Good sketches and a not
 - Try to sketch in 3D!

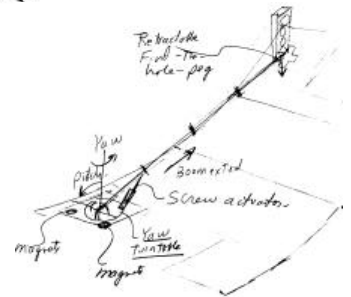
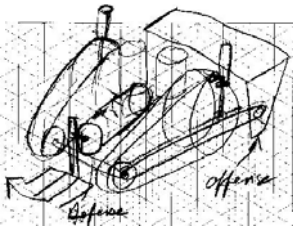
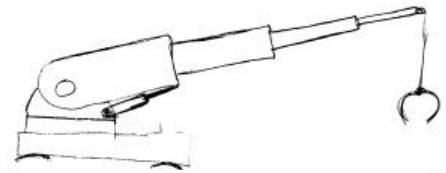
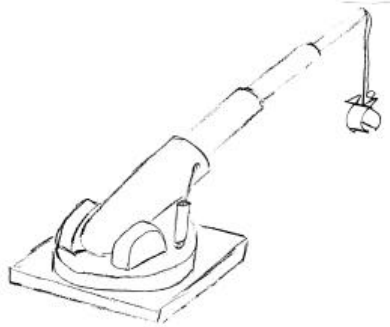
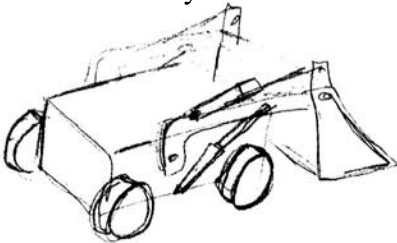

Drawing: *Solid Models*

- Creating a solid model of the environment (Contest table!) helps you build a solid model of your machine, to make sure it will fit!
 - A solid model of the environment lets you make measurements outside of the lab, to make sure your mechanism will fit
- A solid model of a *concept* starts with simple parametric shapes, that will essentially define volumes into which *modules* must fit
 - Detail is added as the design progresses
- Analysis of a solid model can serve as a *Bench Level Experiment*, to illuminate problems and help guide sensitivity studies

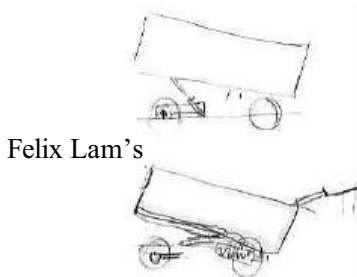

Felix Lam's

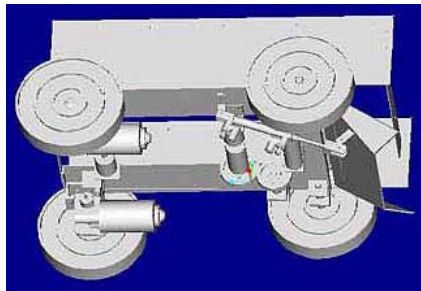

2-13



1/16/2002



Research



- Past contests
- The Internet
- Patent searches

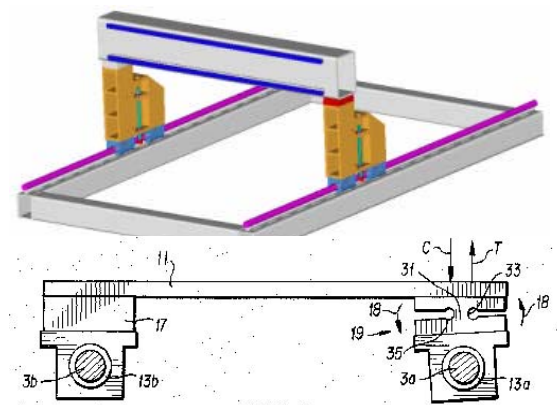
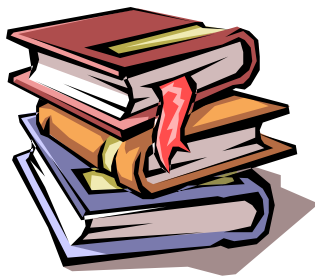

FIG. 3

US Patent 4,637,738

Writing



- Putting it in your own words....
- Lists and Tables
- Narratives
- Poems, raps, ballads...

PROJECT STATUS UPDATE: NOFER TRUNIONS

Work has been proceeding in order to bring to perfection the crudely conceived idea of a machine that will consistently refragitate Nofer Trunions. The current design concept, known as a Turbo Encabulator, supplies inverse reactive current to unilateral phase detractors and thus is capable of automatically synchronizing its internal Cardinal Grammmeters.

The original machine has a base plate of pre-fabulated amulite surmounted by a malleable logarithmic casing in such a way that the two sperving bearings are co-linear with the pentrametric fan. The main winding is of the normal Lotus-O-Delta type, placed into pateodermic semi-blode slots in the stator with every seventh conductor being connected by a non-reversible tremic pipe to the differential girdle spring at the upper end of the grammeter. 41 (yes, 41!) manestically spaced grouting brushes are arranged to feed into the rotor slip stream a mixture of high S value phenolbitatol benzene and 5% ruminative tetra tyliodol hexamine. Both these liquids have a specific pericosity given by:

$$P = 2.5 Cn 6.5$$

where n is the diethetical retribute of temperature phase disposition, and C is Colomondole's annual grilliage constant. Initially, n was measured with the aid of a metapolar diffractive pilfrommeter, but to date nothing has been found to equal the transcendental hopper dactascope.

Undoubtedly, the Turbo Encabulator has reached a high level of technical development. It has been successfully used to produce sucraively modified Nofer Trunions in large volumes. In addition, whenever a bardensen scorn motion is required, it may be employed in conjunction with a drawn reciprocating dingle arm to reduce sinusoidal depletion in the Nofer Trunions' bifurdangled hipniscorn.

Believed to be written decades ago by a long-forgotten soul at Phi Kappa Tau fraternity, Rensselaer Polytechnic Institute

Analysis

- Appropriate Analysis
- Scoring Sensitivity
- Time & Motion
- Power & Strength

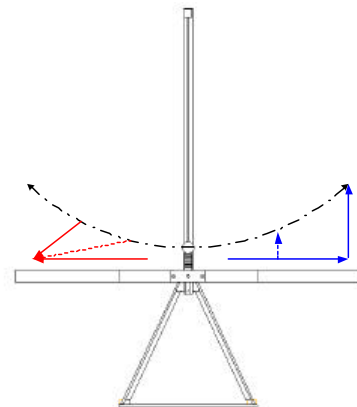
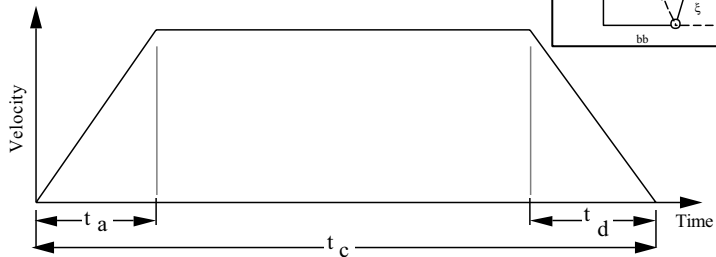
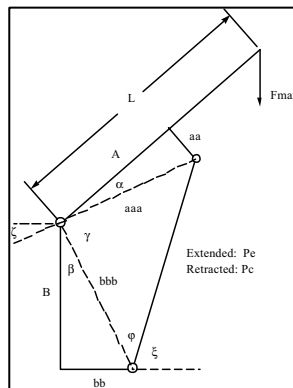
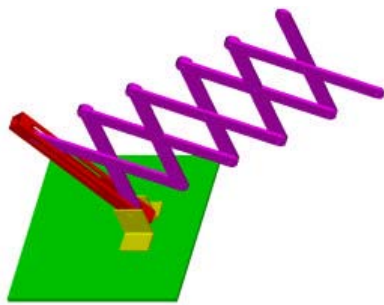

Analysis: *Scoring Sensitivity*

- What gives the greatest score for the least effort:
 - Pendulum?
 - Hockey pucks?
 - Balls?
- What variables affect the score?
 - Ball and puck weight
 - Pendulum travel?
 - ?
- Answer these questions by writing the equations, and then investigating which are the most sensitive parameters
 - Ask yourself: *How can I affect each of these parameters?*
- ***Physics is an AWESOME catalyst to help your brain generate***
- ***Analysis is an awesome lens for focusing effort!***

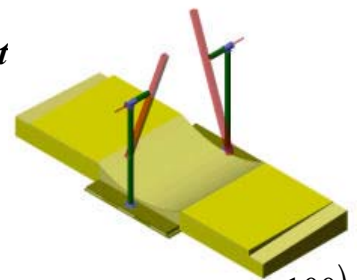
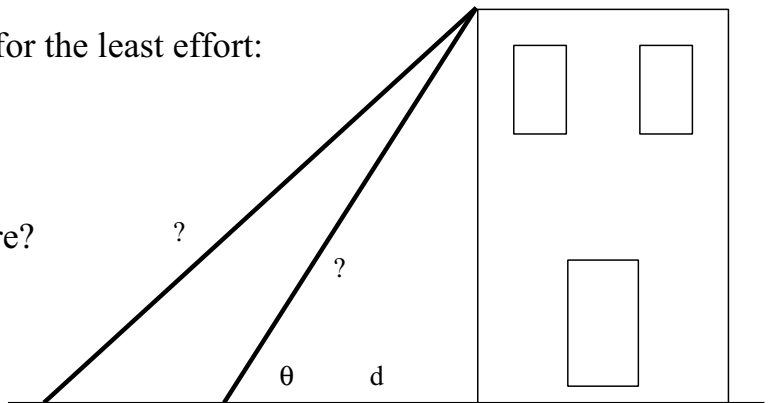

$$Score = \left(\theta_{\text{Total pendulum angular distance traveled in radians}} + 1 \right) \left(m_{\text{total mass in grams of street hockey balls and pucks}} + 100 \right)$$

Analysis: *Appropriate Analysis*

- Appropriate Analysis is a **CRITICAL** part of defining a problem’s bounds and generating creative concepts!
 - If $F = ma$ will answer the question, do NOT bother with relativity!
 - Spreadsheets, MATLAB, FEA...use whatever works best for you to yield an informative and insightful answer in the least amount of time
 - Remember to use analysis to design experiments, and experiments to answer questions when analysis is too difficult
 - If you spend your time pushing on a rope, you will buckle from the strain!
- “Back-of-the-envelope” calculations are a critical part of the early conceptual design phase!
 - Kinematic constraints
 - Beam stresses
 - Power required
 - Tractive force
 - Tipping angle
 - ...
- Too many designers put-off analysis until its too late, and they are stuck trying to detail a design that fundamentally draws vacuum (S%\$KS!)

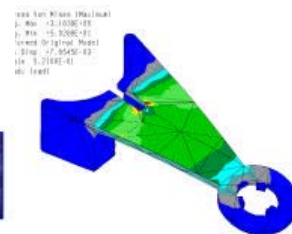
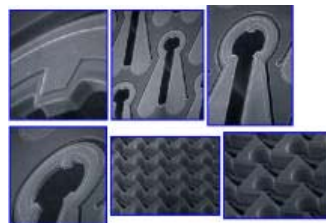

| | A | B | C |
|----|---|-----------------|---------|
| 1 | Width tapered beam design with constant thickness | | |
| 2 | Enter numbers in BOLD | | |
| 3 | Written by Alex Slocum, last updated 4/17/2006 | | |
| 4 | Force, F (lb, grams) | 0.02 | 9.08 |
| 5 | Thickness, t | 2.50E-07 | |
| 6 | Thickness, t | 6.91E-04 | 0.01756 |
| 7 | Length, L (in, mm) | 0.025 | 0.635 |
| 8 | Width at top, a (in, mm) | 0.01 | 0.254 |
| 9 | Width at base, b (in, mm) | 0.03 | 0.762 |
| 10 | resulting slope, m | | 0.8 |
| 11 | Displacement | 2.38913E-09 | |
| 12 | Moment | 0.0005 | |
| 13 | stress (psi) | 209,281 | |
| 14 | deflection (in) | 0.00524 | |
| 15 | straight beam defl | 0.00505 | |

Analysis: *Geometry, Time, & Motion*

- The contest only lasts for N seconds, so do you have the time (and the power!) to do what is needed?
 - Maximum motor power is generated at $\frac{1}{2}$ the motor's no-load speed!
- A simple spreadsheet can help answer these questions

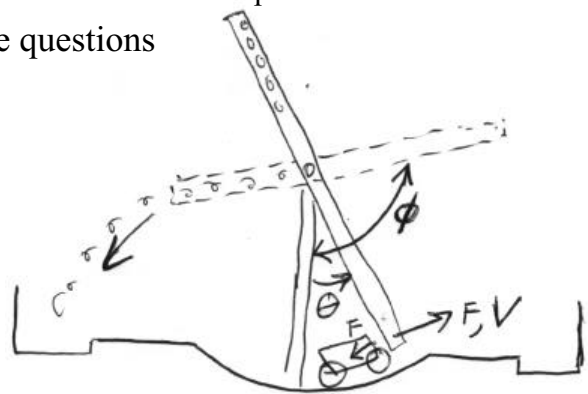
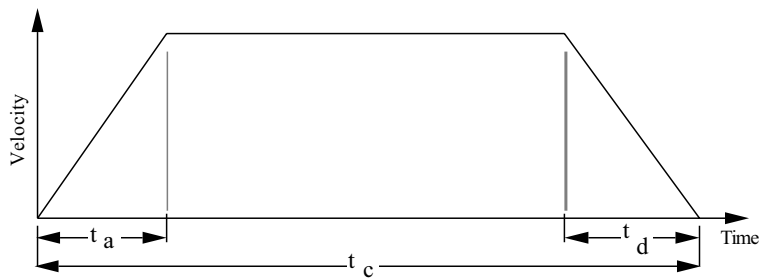

$$D = \frac{a_{\max}}{2} \left(\frac{t_d}{3}\right)^2 + \left(\frac{a_{\max} t_c}{3}\right) \left(\frac{2t_c}{3}\right) + \frac{a_{\max}}{2} \left(\frac{t_c}{3}\right)^2$$

$$a_{\max} = \frac{9D}{2t_c^2}, \text{ maximum acceleration (m/ s}^2 \text{ or rad/ s}^2\text{)}$$

$$v_{\max} = \frac{3D}{2t_c}, \text{ maximum velocity (m/ s or rad/s)}$$

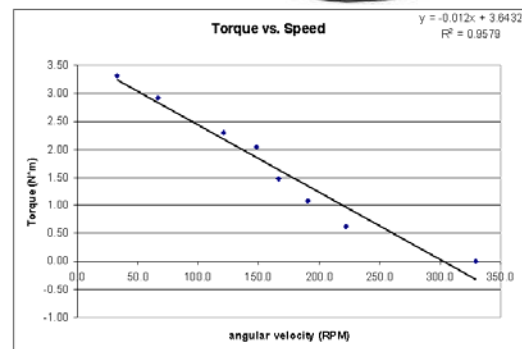

Analysis: *Energy, Momentum, & Strength*

- 1st check for the feasibility of a design: Is available $\text{Power}_{\text{available}} > \text{Power}_{\text{required}}?$
 - Example: Can I raise the pendulum through a 30 degree arc in 1 second using energy stored in constant force springs?
 - $mgh < FL_{\text{extension}}$
- 2nd check for the feasibility of a design: Is $\sigma_{\text{yield}} > \text{applied stress}?$
 - Example: Can I hold M kg extended out L m on a telescoping truss with H m cross section made from D mm welding rod?

$$\sigma = (MgL) \left(\frac{\pi D^2 H}{2} \right)$$

- It is a good idea to be aware of the physical capabilities of the kit materials, and the physical requirements of the scoring methods...

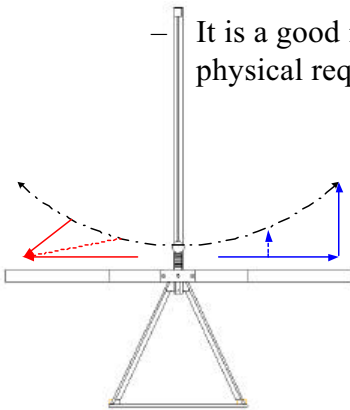

© 2000 Alexander Slocum

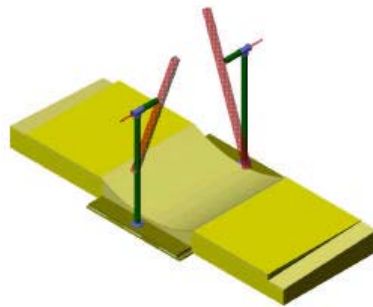

2-20

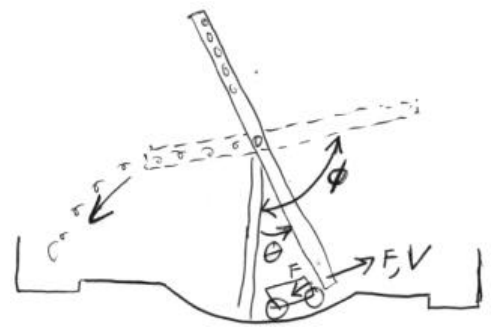

1/16/2002

Evolving Systems

- Individual Thought
- Rohrbach's 635 Method
- Brainstorming
- Design Comparison Methods

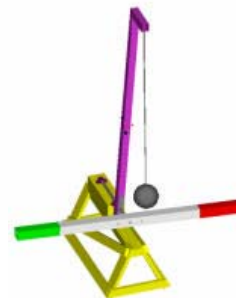
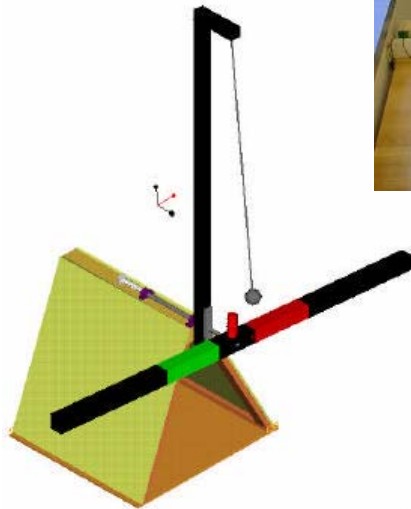
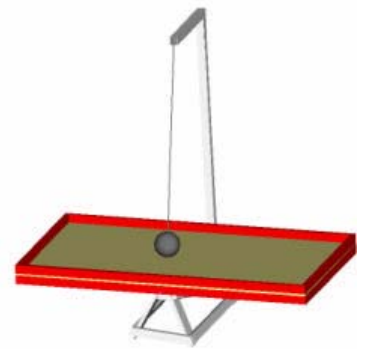
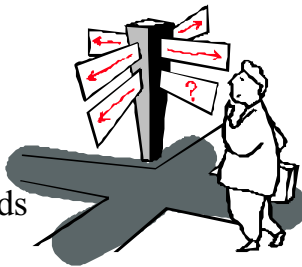

Evolving Systems: *Individual Thought*

- Individual thought is often the most creative
 - Do leisurely things (e.g., long walks) that you know inspire creative thought.
 - Look at what other people have created
 - Look in your home, stores, www, patents
 - Get out of traffic and take alternate routes
 - Sketch ideas and the ideas' principal components
 - Cut out the principal components and pretend they are modular elements
 - Like toy building blocks, try different combinations of components to make different products
 - Pit one idea against another and imagine strategies for winning
 - Take the best from different ideas and evolve them into the best 2 or 3 ideas
- Update the FRDPARRC table and create a *Milestone Report* or *Press Release* for your favorite ideas
 - The FRDPARCC Table (ONE DP per FR) and a large annotated sketch makes an effective infomercial
 - A random person should be able to read your *press release* and fully understand your idea without your having to explain it to them
 - These sheets will be shared with your teammates in the next stage...

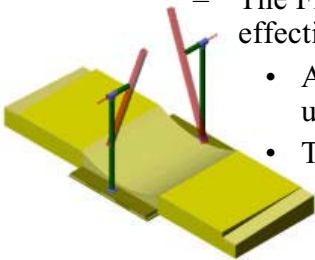

Evolving Systems: *Rohrbach's 635 Method*

- Six (N) people circulate their *Milestone Reports* or *Press Releases* to the other five (N-1) for comments
 - A written record is thus also made of who first had the idea, so personality conflicts are more easily avoided
 - NO TALKING: people make written constructive comments on each other's papers, until everyone has read everyone else's press releases
- This creates a collective mind, so everybody knows what everyone else has been thinking
 - The group mind then works together in a more efficient manner when brainstorming...
 - Very useful for developing *strategies, concepts, & modules*

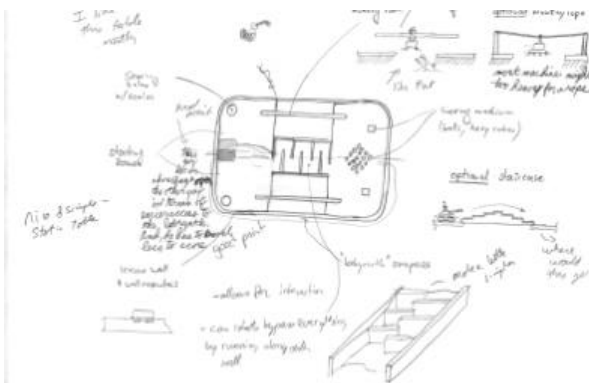

© 2000 Alexander Slocum

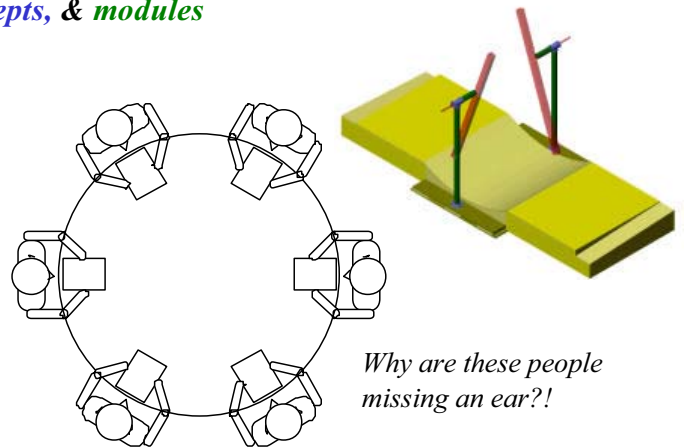

2-23

1/16/2002

Evolving Systems: *Group Brainstorming*

- Brainstorming helps teams solve personal creativity deadlocks and help to ensure something hasn't been overlooked
- Initially let everyone voice their suggestions, then distill ideas
- Group personality factors must be considered:
 - Shy individuals getting run over
 - Aggressive individuals always driving
- An individual's personality often has nothing to do with creativity
 - Careful to avoid conflicts over the issue of who first thought of the idea
 - The people in the group must be willing to take praise or scolding as a group
 - NO pure negatives, only observations with suggestions for improvement:
 - ~~“That design sucks!”~~
 - “I see a low pressure region that can be alleviated by making it blue” ✓

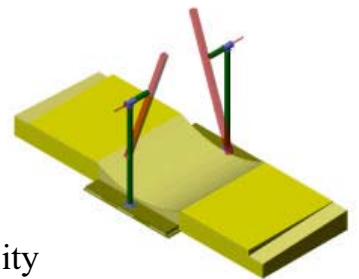

Evolving Systems: *Design Comparison Methods*

- There are many systematic methods available for evaluating design alternatives
 - The simplest method is a linear weighting scheme:
 - You may want to use the list of FRs as the evaluation parameters
 - Apply a relative importance weight to each evaluation parameter
 - Pick one design as a “baseline” (all zeros), and compare the rest (+ or -)
 - Easiest to use provided user bias can be minimized
 - When you find the “best” design, look at other designs that have higher weights and see how those characteristics can be transferred to the “best” design to make it even better!
 - A “Pugh” chart is similar, except that it does NOT use the weighting column!
 - A linear weighting scheme (a series of +, -, 0 wrt a baseline design) will give equal weighting to attributes



| | A | B | C | D | E |
|----|--------------------|--------|---------------|--------------|--------------|
| 1 | | | | | |
| 2 | | | | | |
| 3 | | | | | |
| 4 | | | | | |
| 5 | | | | | |
| 6 | | | | | |
| 7 | | Weight | Tilting Table | Peace Circle | Tilting Beam |
| 8 | Scoring variation | 3 | 0 | -1 | 0 |
| 9 | Dynamic motions | 2 | 0 | 0 | 1 |
| 10 | Crowd appreciation | 1 | 0 | 0 | 0 |
| 11 | Manufacturability | 1 | 0 | 1 | 0 |
| 12 | Transportability | 1 | 0 | 1 | 0 |
| 13 | Scalability | 2 | 0 | 0 | 0 |
| 14 | Base for storage | 1 | 0 | 1 | 0 |
| 15 | | | 0 | 0 | 2 |

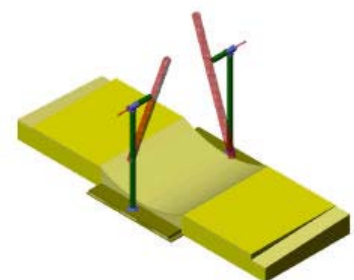

Evolution: *It Never Stops*

- Physically experimenting with the hardware while thinking about all possible variations can produce many creative ideas
 - Sketching, drawing, and solid modeling are powerful creativity catalysts
 - Much has been done by others: Learn from others' failures and successes
 - Writing down your thoughts and dreams can help you to see solutions
 - Analysis can identify areas of high (low) sensitivity and rapidly ascertain feasibility
 - Ideas can evolve rapidly when they are compared to others
- ***Do Not Stop!***

